

NOTES:

1. MANHOLES SHALL MEET OR EXCEED ASTM-C478.
2. MINIMUM WALL THICKNESS SHALL BE 5".
3. ALL MANHOLE SECTIONS SHALL HAVE LIFTING HOLES PROVIDED.
4. MANHOLE SECTION SHALL BE TONGUE AND GROOVED.
5. STEPS SHALL BE CAST IN PLACE WITH A MAX. 16" O.C.
6. MASTIC OR 'O' RING WILL BE ACCEPTABLE.
7. INLET AND OUTLET PIPES MUST BE AT PROPER ELEVATION WITH OPENING CAST IN MANHOLE BY MANUFACTURER.
8. MANHOLES MAY BE CONSTRUCTED CONCENTRIC IF TOTAL HEIGHT IS 5' OR LESS.
9. DISTANCE FROM BOTTOM OF TROUGH TO SHELF EDGE TO BE 70% DIAMETER OF OUTLET PIPE.
10. 10% SLOPE ON SHELF - ALL DIRECTION.
11. MIN. 15" WIDTH OF SHELF (BENCH).
12. DROP MANHOLE REQ'D. IF DIFFERENCE IN INCOMING SEWER ELEVATION AND MANHOLE INVERT IS EQUAL TO OR EXCEEDS 18". SLIDES SHALL BE INSTALLED WHEN LESS THAN 18". MINIMUM INSIDE DIAMETER 5'.
13. ADJUST ELEVATION OF FRAME AS REQUIRED USING CONCRETE GRADE RINGS. USE OF COMPOSITE FRAME AND COVERS IS ACCEPTABLE. SEE BCWS APPROVED PARTS LIST.
14. IF FLOWABLE FILL IS USED, ALL PIPES AND FITTINGS MUST BE POLY-WRAPPED.
15. PIPE ENTRY INTO MANHOLE SHALL BE SEALED WITH INSTALLED BOOT AND NON SHRINK GROUT.
16. MANHOLE SHALL HAVE BCWS APPROVED FRAME/COVER DEPENDING ON APPLICATION. IF EPOXY COATED, MUST HAVE COMPOSITE FRAME/COVER INSTALLED.
17. SEAL INSIDE BARREL SEAMS WITH NON SHRINK GROUT.
18. MANHOLES 12' OR GREATER IN DEPTH SHALL HAVE AN INSIDE DIAMETER OF 5'.

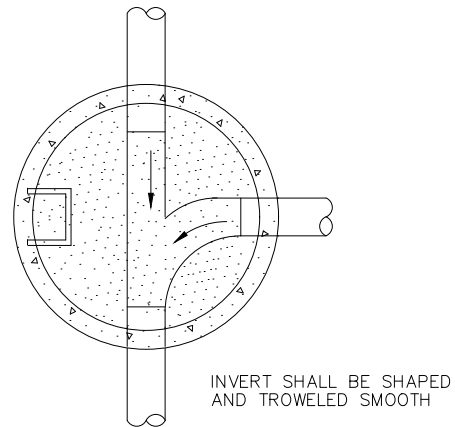

PRECAST CONCRETE MANHOLE

NOT TO SCALE

SEWER PANEL 2A

**BERKELEY COUNTY WATER AND SANITATION
POTABLE WATER & SANITARY SEWER STANDARDS**

REVISED 07/09/2025